

XS SERIES

Resistive Load Bank

400kW



ISO 9001:2015 Registered



Standard Features

1. Lightweight aluminum body
2. NEMA 3R protected control panel with digital meter and type B data port
3. Lockable casters for easy maneuvering (can be removed for permanent install)
4. Rigid louvers to prevent rain ingress
5. Quick high speed cooling fans
6. Forklift channels
7. 400 amp camlock power connections

Applications

- Generator Maintenance
- Uninterrupted Power Supplies
- Data Centers
- Renewable Energy
- OEM's

Building on its experience with resistors in the locomotive and mining truck world, Mosebach's XS400 load bank offers you a continuous load at various voltages in a compact, lightweight enclosure. The XS400 is the smallest load bank in its class.

The digital meter allows you to measure power, voltage,

current and frequency while also allowing you to record the data as you do your testing.

Power connections are easily done with our camlock connections. External power is used for blower and control power if desired. You should be up and testing within minutes of connecting your power source.

MOSEBACH MANUFACTURING COMPANY

1417 McLaughlin Run Rd. | Pittsburgh, PA 15241 | 412-220-0200
loadbankquotes@mosebachresistors.com

www.mosebachresistors.com

XS SERIES

Resistive Load Bank 400kW



XS400

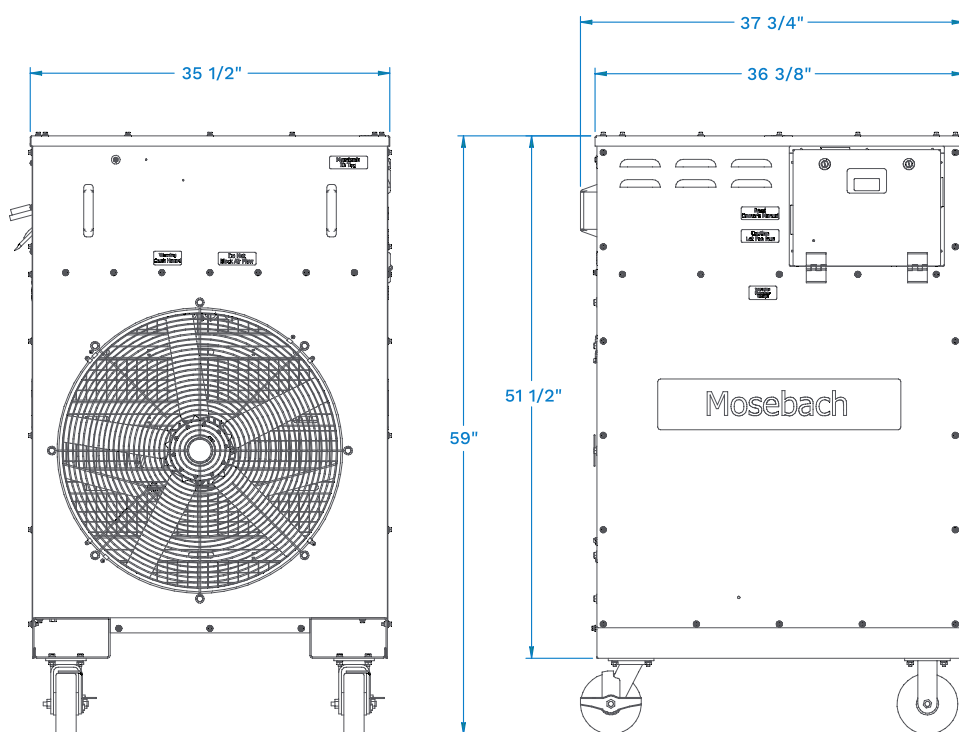

Option Configuration (Select One in Each Group)

CAPACITY

- 400 kW

VOLTAGE

- 600 VAC 3-Phase 60hz
- 480 VAC 3-Phase 60hz
- 240 VAC 3-Phase 60hz
- 240/480 VAC 3-Phase 60hz

CONNECTION METHOD

- Cam-Lock Interface Kit

Standard Configuration

Digital Meter

- To measure power, current, voltage and frequency
- Data logging to store tests to laptop

Safety

- Over temperature and over voltage sensors
- Ground camlock

Option Add-Ons (Select Desired)

OPTIONAL KITS

- Remote Control Kit MURC
- Mobility Kit (Casters)
- Outdoor Installation Kit
- Outdoor Installation Kit w/Louver Covers
- Integral Space Heater Kit
- Extended 2 Year Warranty
- Extended 3 Year Warranty
- Starter Spare Parts Kit

OPTIONAL ACCESSORIES

- Equipment Trailer
- Equipment Trailer w/Motorized Cable Reels
- Cable Reel Enclosure
- 25 ft. Cable Set
- 50 ft. Cable Set
- 100 ft. Cable Set
- Nationally Recognized Test Lab (NRTL) Approval

Model No.	kW	Resolution (kW)	Dimensions (in.) W x D x H	Voltages	kW @ 1/2 Voltage
XS400	400	5	35 x 38 x 59	480/240	400

MOSEBACH MANUFACTURING COMPANY

1417 McLaughlin Run Rd. | Pittsburgh, PA 15241 | 412-220-0200
loadbankquotes@mosebachresistors.com

www.mosebachresistors.com

XS SERIES

Resistive Load Bank

400kW



Multi-Unit Controller Software

Mosebach's Multi-Unit Remote Controller Software is designed to help manage a single load bank or multiple load banks as one. It is able to be installed and run on any laptop.

The hardware consists of an I/O card that is installed in each load bank. The MURC™ can help manage a group of load banks to get the full load that is needed at the testing site.



Mosebach's Cross Wire Resistors

Mosebach's Cross Wire Resistor have no ceramics and therefore are lighter and more durable than any other resistor on the market today. The resistors are supported by high temperature Mica supports that have been proven in Dynamic Braking Systems for locomotives and mining trucks all over the world. We are so confident in our resistor technology they come with a 2 year warranty, standard!

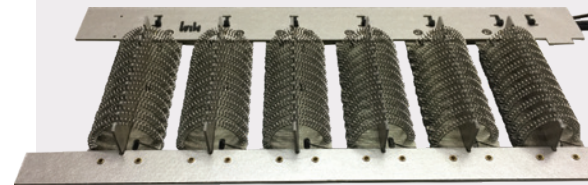

XS-SERIES 01/19

MOSEBACH MANUFACTURING COMPANY

1417 McLaughlin Run Rd. | Pittsburgh, PA 15241 | 412-220-0200
loadbankquotes@mosebachresistors.com

www.mosebachresistors.com