

**SPECIFICATIONS**

MAX VOLTAGE - 600VAC 3 $\phi$   
 RATED CURRENT - 400 A  
 STANDARDS - UL508A  
 ENCLOSURE RATING - NEMA 3R  
 REF. ES100145SE  
 DURABILITY - 6050 CYCLES  
 COLOR - RAL7035 LIGHT COLOR  
 EST SHIPPING WEIGHT - 450LBS

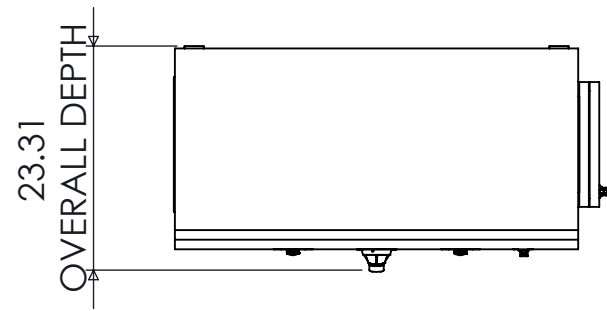

TOP VIEW

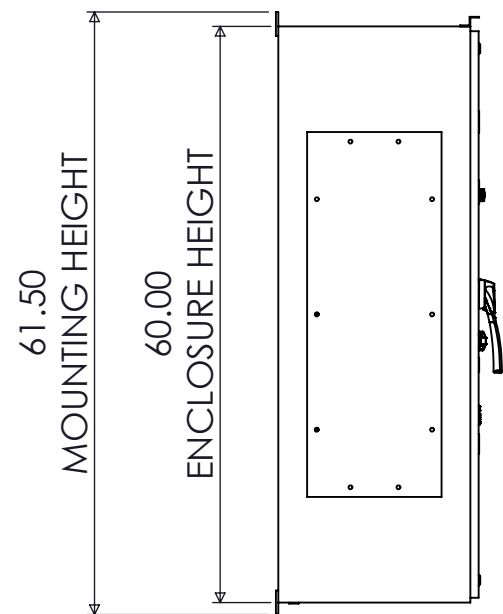

SIDE VIEW

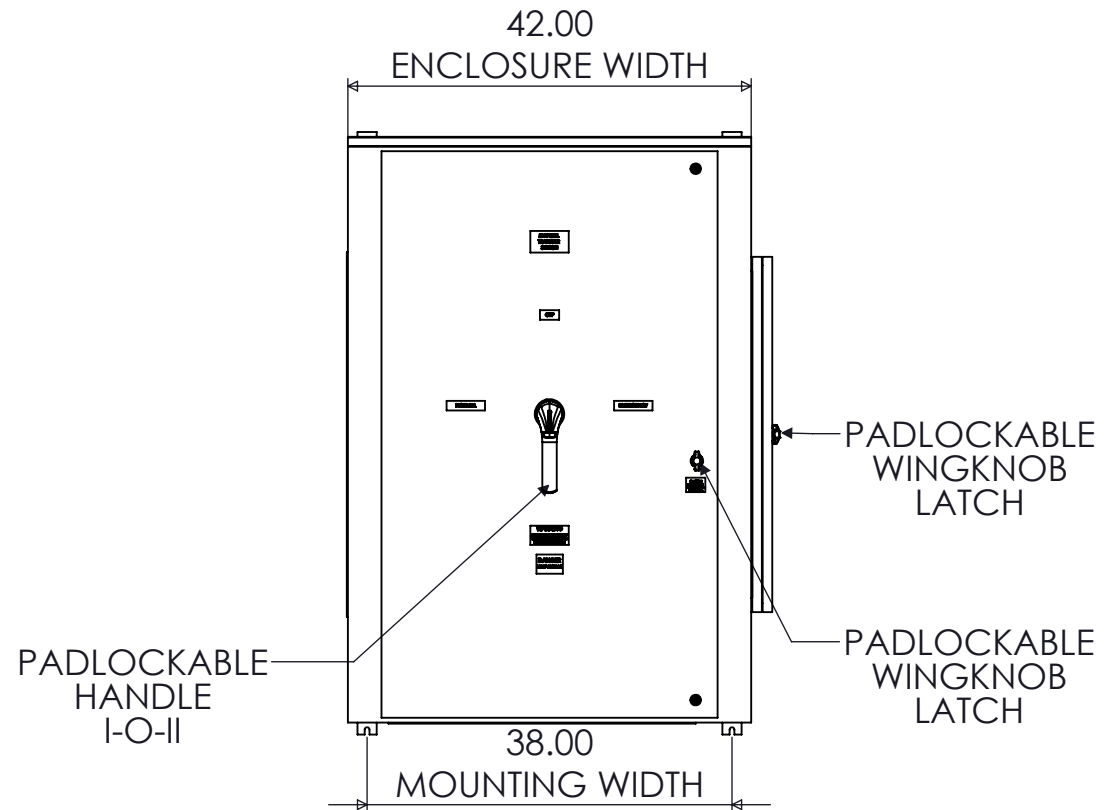

FRONT VIEW

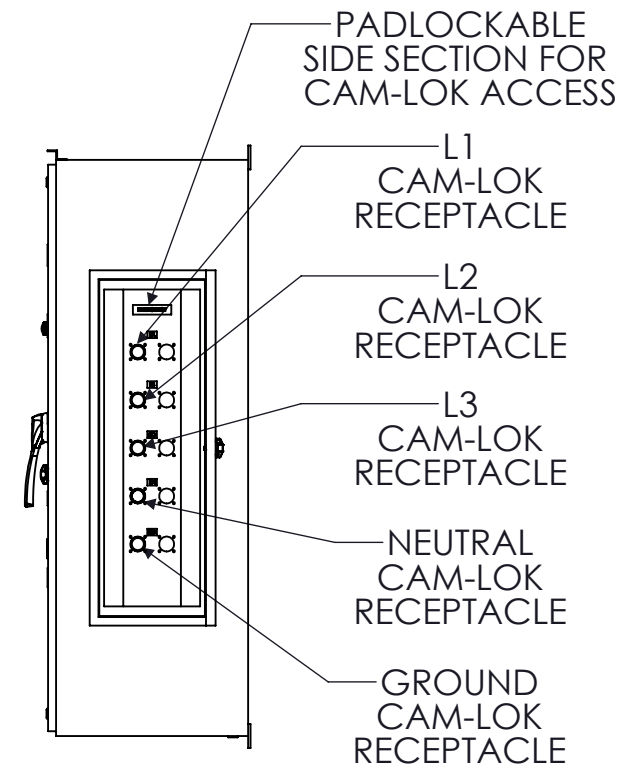

SIDE VIEW

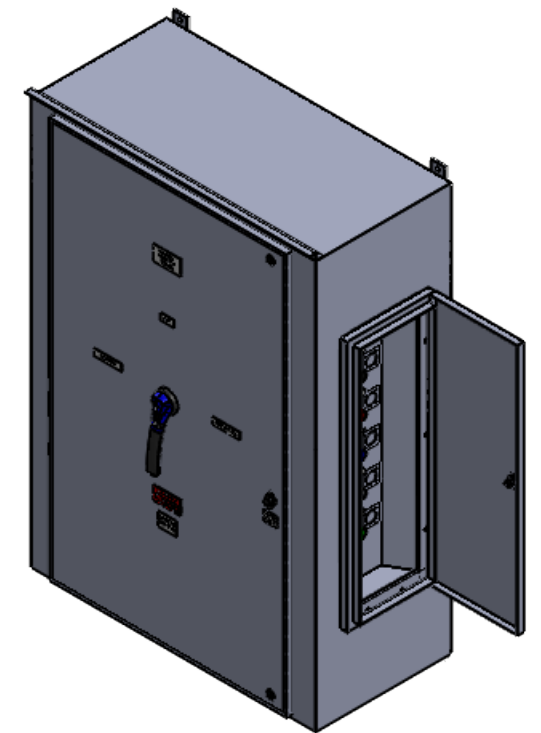

DIMETRIC VIEW

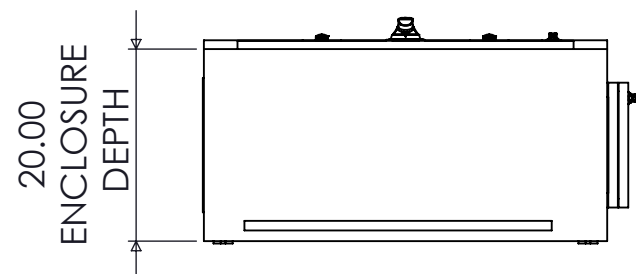

BOTTOM VIEW

**RECEPTACLE/COVER COLOR SCHEME**

	L1	L2	L3	N	GND
240VAC	BLK	RED	BLU	WHT	GRN
480VAC	BRN	ORG	YEL	WHT	GRN
600VAC	BLK	BLK	BLK	WHT	GRN

**400A SE-RATED 4-POLE NEMA 3R MANUAL TRANSFER SWITCH WITH CAM-LOKS (RIGHT)**

REV	DESCRIPTION	DATE	DRAWN	JG
0	ORIGINAL RELEASE	2/16/18	CHECKED	
			SUP. NO	
			SUP. BY NO	
			PANEL NO	
			BUIL. NO	
			GROUP NO	
			ORDER NO	

DRAWING TYPE  
**DIMENSIONAL**

DRAWING NUMBER  
**STS400N3RSE4CR**



9900 TWIN LAKES PARKWAY  
 CHARLOTTE, NC 28269  
 704-596-5617  
 PSICONTROLSOLUTIONS.COM

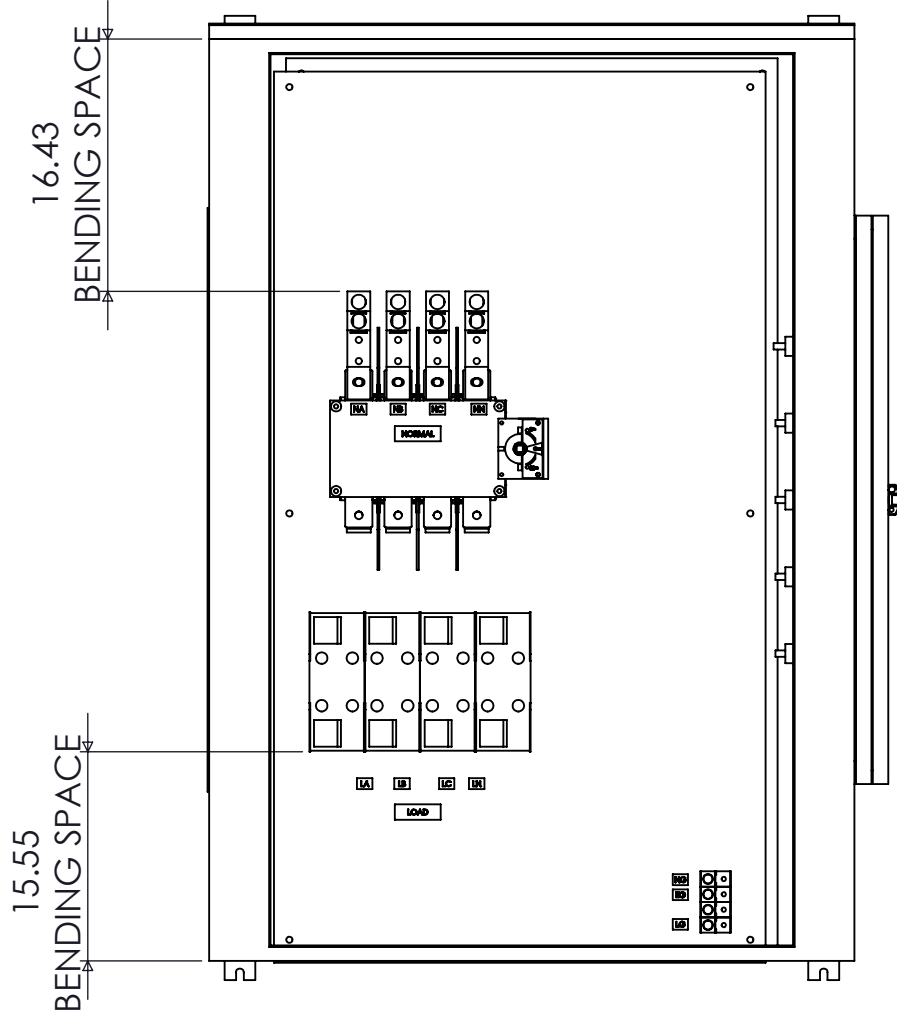

FRONT VIEW  
DOOR REMOVED

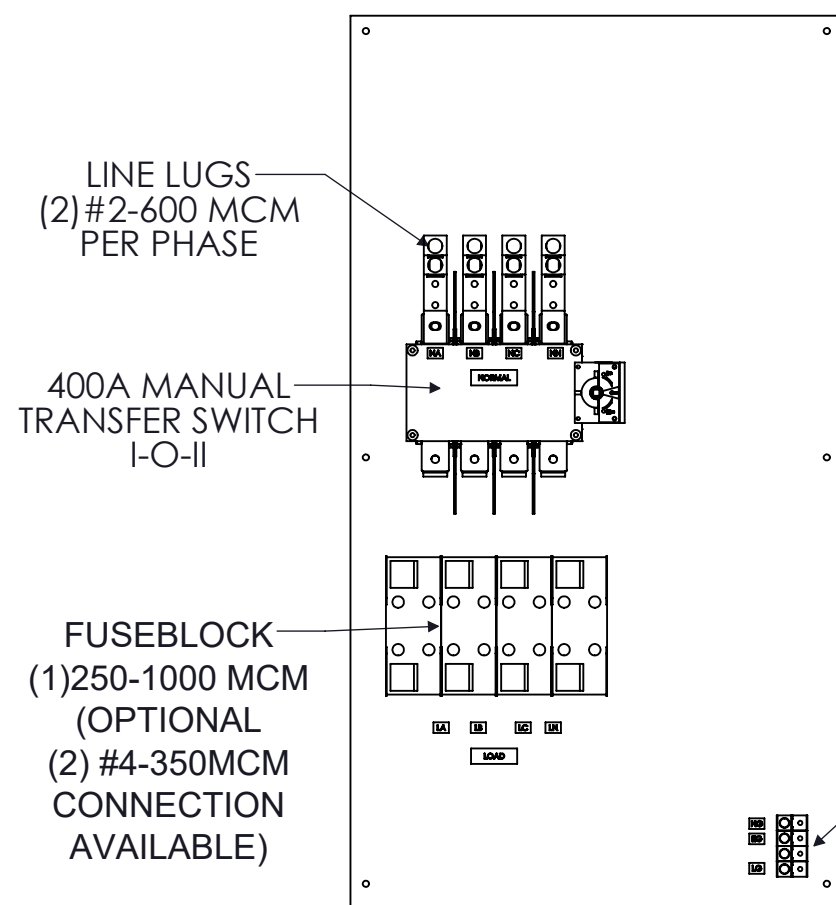

FRONT VIEW  
ENCLOSURE REMOVED

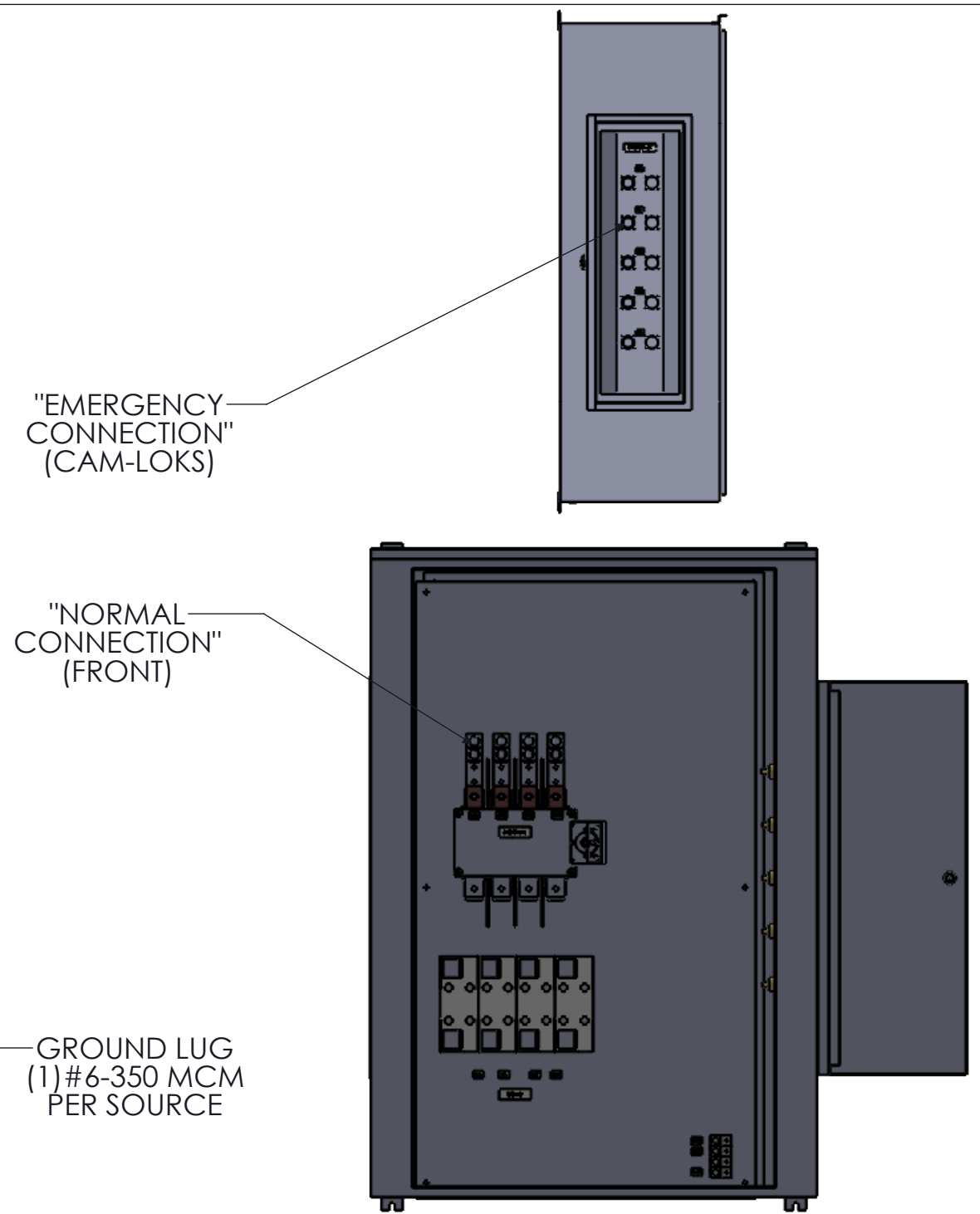

FRONT VIEW  
DOOR REMOVED

NOTE: FUSES PROVIDED IF PURCHASED  
208-240VAC : FRN-R-400  
480-600VAC : LPJ-400SP



9900 TWIN LAKES PARKWAY  
CHARLOTTE, NC 28269  
704-596-5617  
PSICONTROLSOLUTIONS.COM

400A SE-RATED 4-POLE NEMA 3R MANUAL TRANSFER SWITCH WITH CAM-LOKS (RIGHT)				
REV	DESCRIPTION	DATE	DRAWN	JG
0	ORIGINAL RELEASE	2/16/18	CHECKED	
			SUP. NO	
			SUP. BY NO	
			PANEL NO	
			BUL. NO	
			GROUP NO	
			ORDER NO	

DRAWING TYPE	OUTLINE
DRAWING NUMBER	STS400N3RSE4CR