



# ***Generator Tap Box***

## **Instruction Manual**

**400 – 4000 Amp**



# WARNING

**Before Installation READ THIS MANUAL carefully to learn how to properly install, operate and maintain this unit. Personal injury and /or equipment damage may result by failing to pay attention to the vital safety information and instructions in this manual.**

**RETAIN THIS MANUAL WITH THE UNIT. This technical manual contains IMPORTANT SAFETY DATA and should be kept with the unit at all times.**



## **Table of Contents**

	<b><u>Page</u></b>
<b>1. INTRODUCTION</b>	<b>4</b>
<b>2. RECEIVING, HANDLING, and STORAGE</b>	<b>5</b>
<b>3. INSTALLATION</b>	<b>6</b>
<b>4. OPERATION</b>	<b>7</b>
<b>5. MAINTENANCE</b>	<b>8</b>
<b>6. TROUBLESHOOTING</b>	<b>8</b>
<b>7. OPTIONAL FEATURES</b>	<b>8</b>
<b>8. WARRANTY</b>	<b>9</b>

## 1.0 INTRODUCTION

Generator Tap Boxes are designed to easily connect temporary power from a portable generator to a building or plant. PSI Control Solutions' Generator Tap Box is an enclosed junction box for both portable generator Cam-Lok and hard-wired connections. The assembly consists of an enclosure with front and bottom access door and removable interior cover, along with Cam-Lok receptacles, busbar and mechanical lugs. Figure 1 depicts a basic application of the Generator Tap Box integrated with a transfer switch. When utility failure occurs, quickly connect a portable generator to the tap box via Cam-Lok connectors and transfer the load to the generator at the transfer switch. The Generator Tap Box is typically mounted outdoors and hardwired to the indoor switchboard or transfer switch.

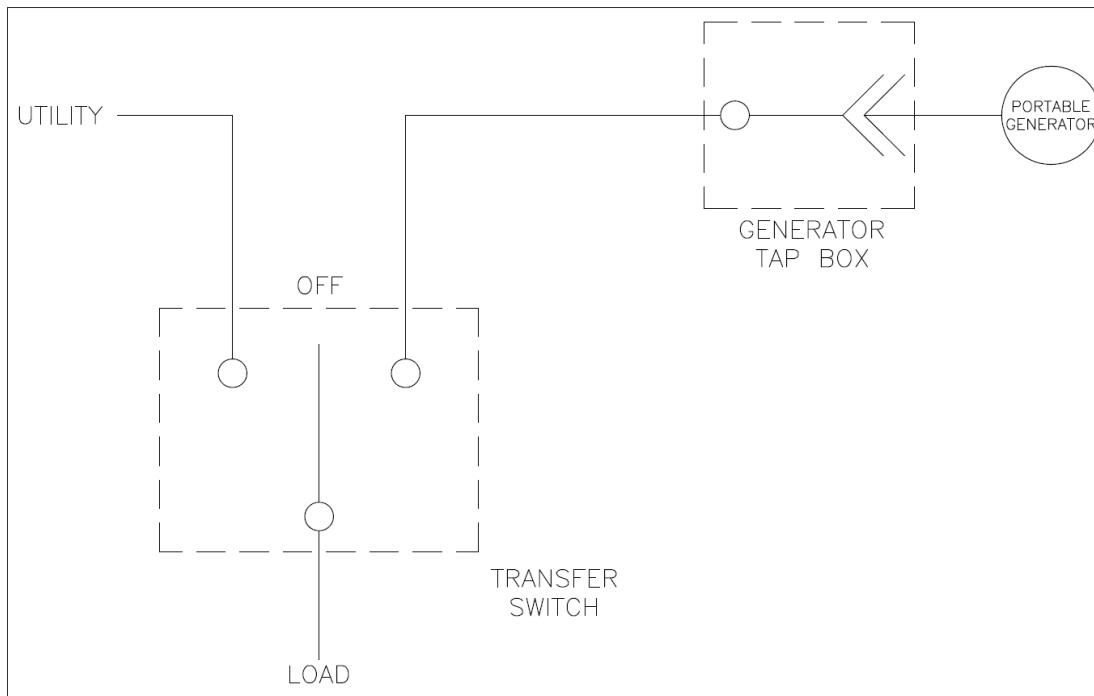

**Figure 1**  
**Typical Generator Tap Box Application**



PSI Control Solutions' Generator Tap Boxes are available with the following offerings.

400-4000A  
100-240VAC Single Phase  
208-600VAC Three Phase  
Fully-Rated Neutral  
NEMA 3R or 316SS 3R Enclosure  
Male or Female Cam-Lok Receptacles  
Mechanical Lugs or Pre-drilled Busbar for Compression Lugs  
Phase Rotation Protection

## **2.0 RECEIVING, HANDLING, and STORAGE**

### **2.1 RECEIVING**

After receiving the Generator Tap Box, unpack the unit and check for any damage that may have occurred during shipment.

### **2.2 HANDLING**

The following guidelines are provided to help avoid personal injury and equipment damage during handling.

- A. Follow the manufacturer's handling instructions for the specific equipment.
- B. Handle the Generator Tap Box with care, to avoid damage to components and to the enclosure or its finish.
- C. Ensure the moving means is capable of handling the entire weight of the Generator Tap Box. **NOTE:** Weights are not distributed evenly.

### **2.3 STORAGE**

If the Generator Tap Box is to be stored for any length of time prior to installation, restore the packaging for protection during that period. Where conditions permit, leave the packing intact until the Generator Tap Box is at its final installation position. When packing is removed, cover the top and openings of the equipment during the construction period to protect them against dust and debris



### 3.0 INSTALLATION



**It is the customer's responsibility to insure that all local, regional and national codes and standards are correctly followed.**

### 3.1 MOUNTING LOCATION

It is the responsibility of the customer to determine the final mounting location of the Generator Tap Box before installation. Refer to the included dimensional drawing for mounting dimensions. All Generator Tap Boxes should be located at a reasonable distance from the switchgear or transfer switch. The location should be chosen to allow easy access from the portable generator.

### 3.2 CABLE ENTRY

Generator Tap Boxes are shipped from the factory with no holes for cable entry. Any enclosure penetrations for cable entry must be provided in the field. Conduits should be installed to prevent moisture or water from entering and accumulating within the enclosure. All conduits (including stubs) should be bonded to the Generator Tap Box. All conduits should be chosen to maintain the appropriate NEMA rating and located in areas recommended by the manufacturer to avoid cable interference with structural members and live components.

### 3.3 CONDUCTOR ROUTING

Provisions should be made to locate conductors in the Generator Tap Box to avoid physical damage and to avoid overheating. The conductors should be secured in order to withstand available short-circuit currents. Follow the manufacturer's instructions for lacing or bracing cables. The largest practical bending radius should be maintained to avoid insulation damage and loose terminals. Please consult and follow appropriate NEMA Bending Radius standards.

### 3.3 HARDWIRED POWER CONNECTIONS

Refer to the drawings in the drawing packet provided for customer connections prior to installing. The interior cover should be removed to expose the hardwired connections. It is the responsibility of the customer to ensure the field conductors are sized appropriately. Ensure there is no portable generator connected before making the



connections. The sequence for connection should be as followed: equipment grounding conductor, grounded circuit conductor if provided (neutral), ungrounded circuit conductors. Refer to the torque label on the door interior for torque requirements. If compression lugs are to be used, it is the responsibility of the customer to install and crimp with the appropriate tools and components.

Care should be exercised in stripping the insulation from the conductors to prevent the conductor from “nick” or “ring”. For aluminum, clean all oxide from the stripped portion and immediately apply inhibiting compound. Installation of cables should be done at temperatures above freezing to prevent cable insulation from cracking or splitting due to cold, unless the cable is suitable for installation at temperatures below freezing.

#### 4.0 OPERATION



### WARNING

**USER SHOULD READ THROUGH THIS MANUAL BEFORE OPERATING TO AVOID INJURY OR EQUIPMENT DAMAGE.**

#### 4.1 CAM-LOK POWER CONNECTIONS

Refer to the drawings in the drawing packet provided for customer connections prior to installing. Before connecting any leads to the Generator Tap Box, ensure the portable generator is not energized. Ensure the portable generator supplying the tap box is fitted with the appropriate gender Cam-Lok plug that corresponds with the Generator Tap Box receptacle. Route the cables through the bottom access door opening. The sequence for connection should be as followed: equipment grounding conductor, grounded circuit conductor if provided, ungrounded circuit conductors. Disconnection should be in the reverse order. Before disconnecting, ensure the portable generator is not energized.

#### 4.2 GENERATOR TAP BOX OPERATION

After the portable generator leads are connected to the tap box, close the main door and start the generator. Once the generator is online, transfer the load at the switchboard or transfer switch. After the preferred source returns, transfer the load back to the normal source and shut down the portable generator. Ensure the portable generator is completely shut down before removing the power leads from the Generator Tap Box.



## **WARNING!**

**DO NOT TOUCH THE GENERATOR TAP BOX UNTIL ALL POWER IS DISCONNECTED. SHOCKS, BURNS OR DEATH MAY RESULT FROM HIGH VOLTAGE**

### **5.0 MAINTENANCE**

The following checks should be performed as a part of routine maintenance.

- A visual inspection of the unit should be performed every month.
- The Generator Tap Box should be kept clean of dust and moisture. **DO NOT USE A BLOWER TO CLEAN** the unit. Always use a clean dry cloth or vacuum.
- Check all wiring connections.
- Visually inspect the conductive components for surface deposits and pitting. This inspection should be performed annually.

### **6.0 TROUBLESHOOTING**



## **WARNING**

**DISCONNECT ALL POWER SUPPLY SOURCES TO THE GENERATOR TAP BOX BEFORE SERVICING TO PREVENT SHOCK OR ACCIDENT HAZARD**

Before troubleshooting, perform the following checks:

- A. Visual Inspection for physical damage.
- B. Ensure the portable generator is operational.
- C. Ensure the Cam-Lok connectors are secured in their receptacles.
- D. Ensure all hardwired connections are secure.

As-built schematics and panel outlines are provided as a part of the drawing packet supplied with each Generator Tap Box.

### **7.0 OPTIONAL FEATURES**

#### **7.1 PHASE ROTATION PROTECTION**

Phase rotation protection is an optional feature intended to protect against incorrect phase sequence in three phase systems. If selected, an indication light on the door will





be provided. The indication light will energize if the phase sequence is correct (ABC). If the sequence is anything other than ABC, the indication light will not be illuminated.

## 8.0 WARRANTY

### WARRANTY

Seller warrants that the Products manufactured by it and delivered hereunder will be free from defects in material and workmanship for a period of twelve (12) months from date of shipment. Buyer shall be obligated to promptly report any failure to conform to this warranty, in writing to Seller within said period, whereupon Seller shall, at its option, correct such nonconformity, by suitable repair to such Goods or, furnish a replacement part F.O.B. point of shipment, provided Buyer has stored, installed, maintained and operated such Goods in accordance with good industry practices and has complied with specific recommendations of Seller. **This warranty does not cover reimbursement for labor, gaining access, removal, installation, temporary power or any other expenses, which may be incurred in connection with repair or replacement.** SELLER MAKES NO OTHER WARRANTY OR REPRESENTATION OF ANY KIND WHATSOEVER, EXPRESS OR IMPLIED, EXCEPT THAT OF TITLE, AND ALL IMPLIED WARRANTIES OF MERCHANTABILITY AND FITNESS FOR A PARTICULAR PURPOSE, AND HEREBY DISCLAIMED.

Correction by Seller of nonconformities whether patent or latent, in the manner and for the period of time provided above, shall constitute fulfillment of all liabilities of Seller for such nonconformities whether based on contract, warranty, negligence, indemnity, strict liability or otherwise with respect to arising out of such Goods. The Buyer shall not operate Goods which are considered to be defective, without first notifying Seller in writing of its intention to do so. Any such use of Goods will be the Buyer's sole risk and liability.