

**SPECIFICATIONS**

MAX VOLTAGE - 480VAC 3 $\phi$   
 UL1008 RATED CURRENT - 100 A  
 STANDARDS - UL508A  
 ENCLOSURE RATING - NEMA 1  
 REF. ES100145SE3  
 SWITCH SCCR - 100kA @ 480VAC  
 DURABILITY - 6050 CYCLES  
 EST SHIPPING WEIGHT - 150LBS

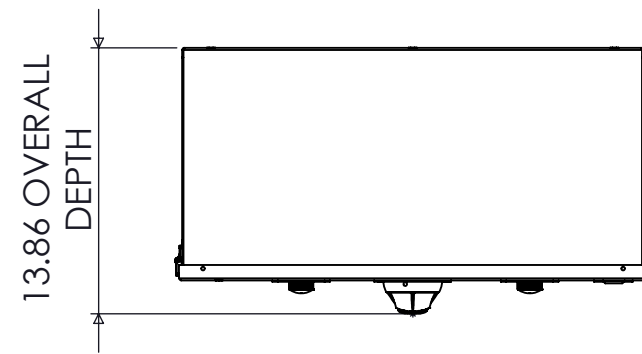

TOP VIEW

24.00  
ENCLOSURE WIDTH

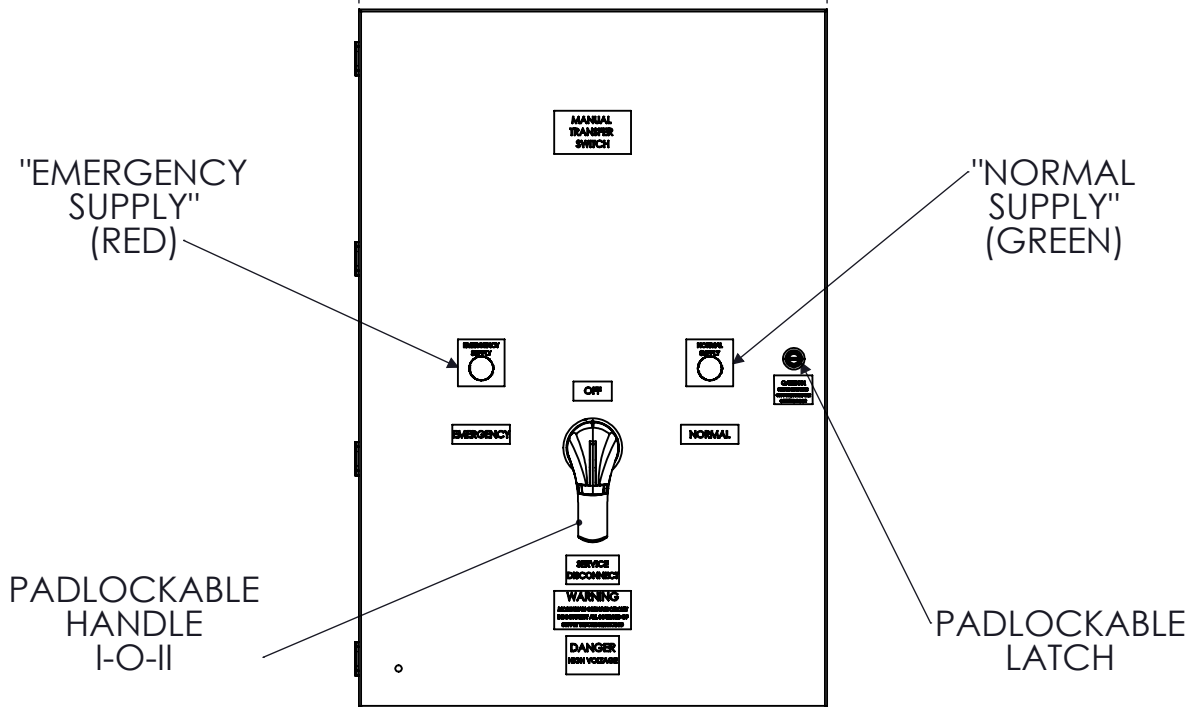

FRONT VIEW

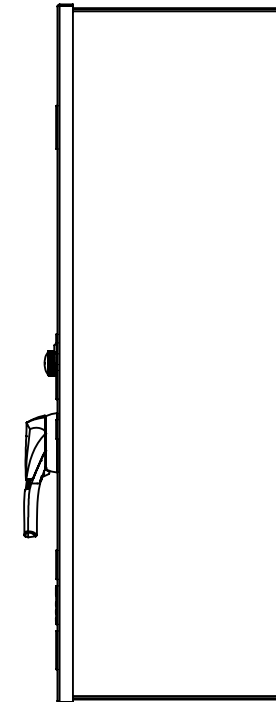

RIGHT VIEW

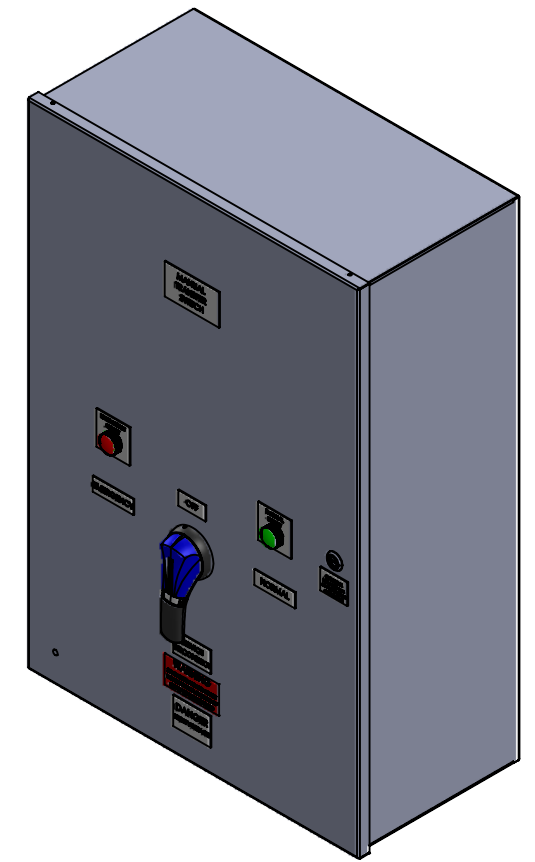

DIMETRIC VIEW

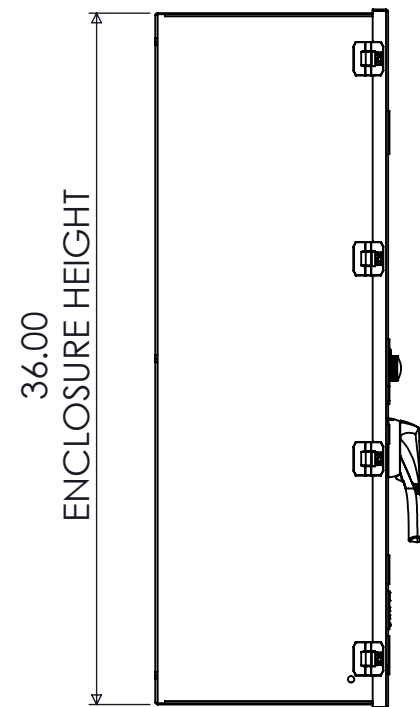

LEFT VIEW

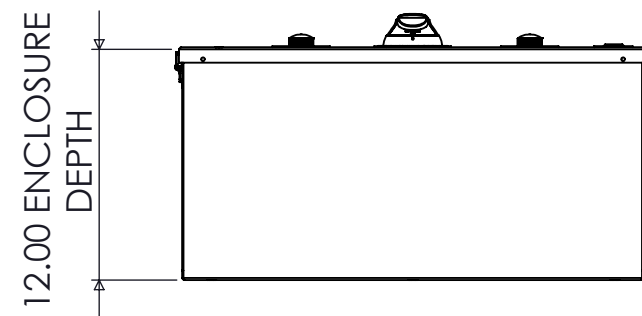

BOTTOM VIEW

100A SE-RATED 3-POLE NEMA 1 MANUAL TRANSFER SWITCH

REV	DESCRIPTION	DATE	DRAWN	C. JUNG	
0	ORIGINAL RELEASE	9/15/17	CHECKED		
1	FUSES MOVED	10/19/21	SUP. NO		DRAWING TYPE
2	HARD BUS ADDED	02/27/22	SUP. BY NO		DIMENSIONAL
			PANEL NO		DRAWING NUMBER
			BUL. NO		STS100N1SE3
			GROUP NO		
			ORDER NO		

**PSI**  
Power & Controls  
 9900 TWIN LAKES PARKWAY  
 CHARLOTTE, NC 28269  
 704-596-5617  
 PSICONTROLSOLUTIONS.COM

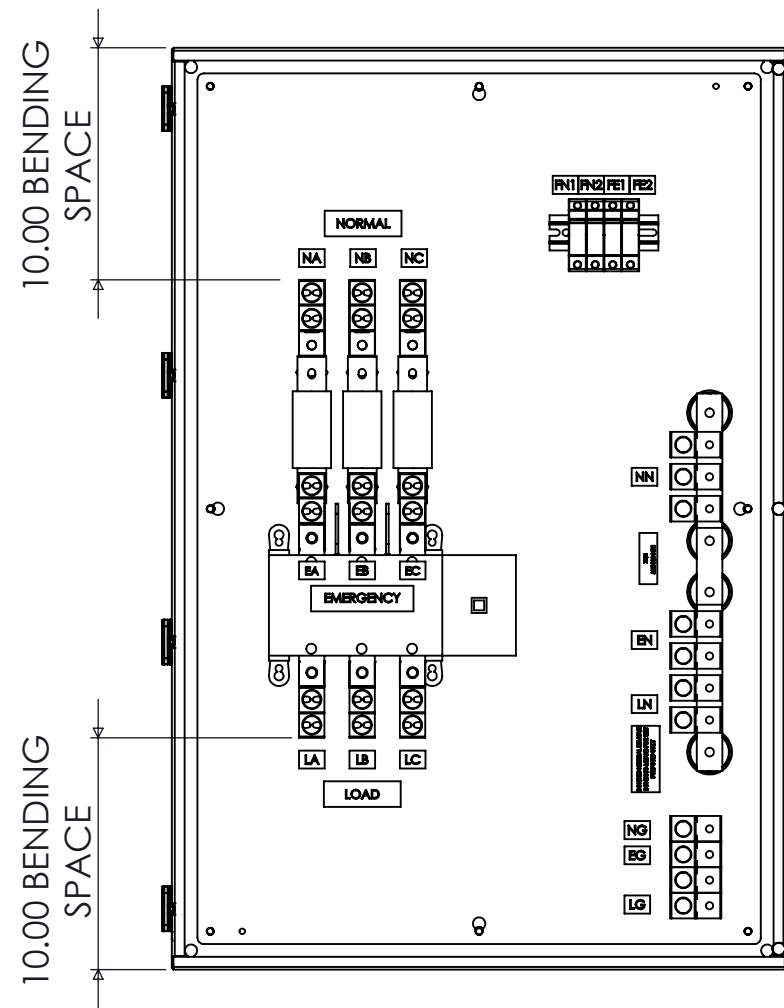

FRONT VIEW  
DOOR REMOVED

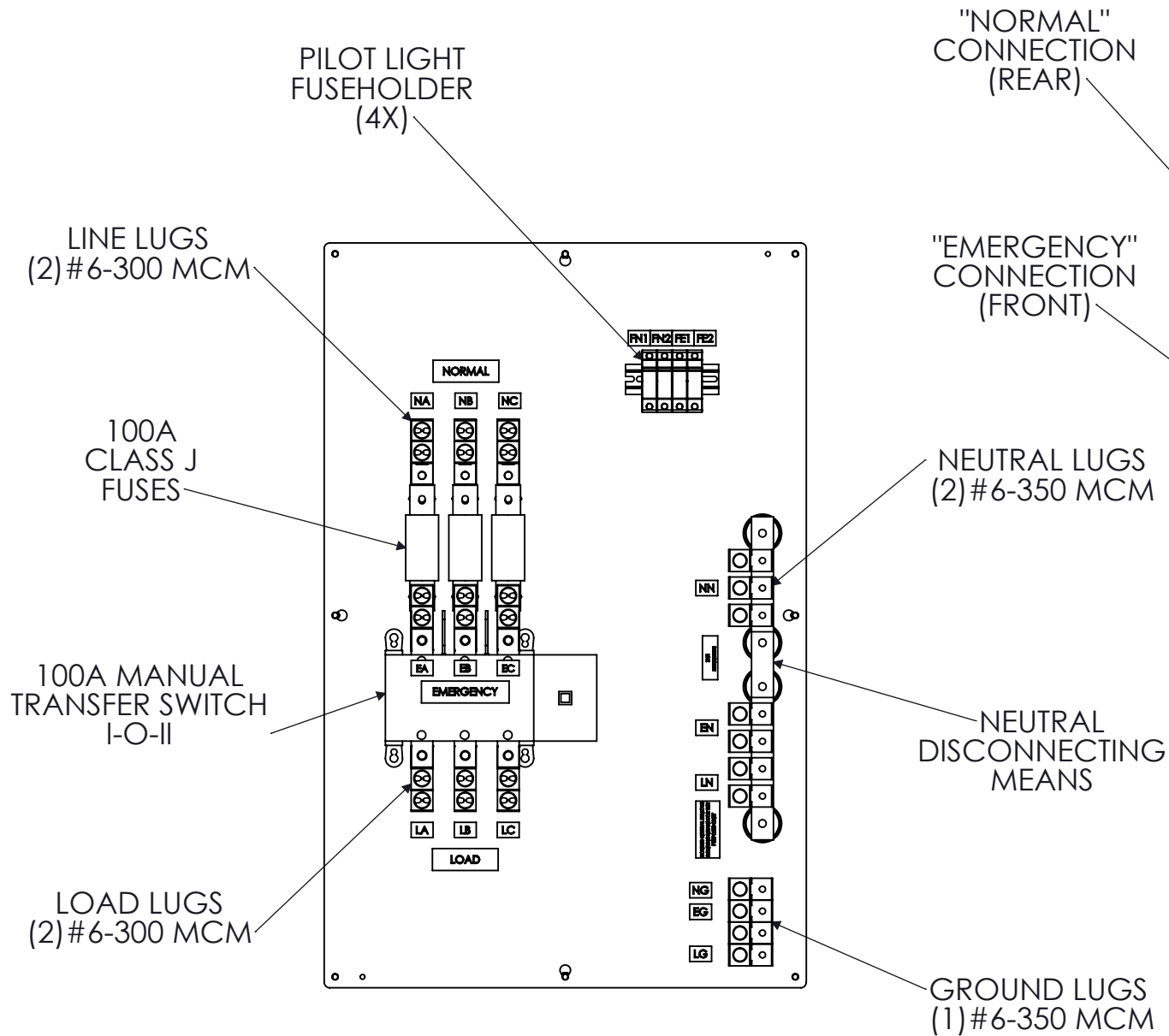

FRONT VIEW  
ENCLOSURE REMOVED

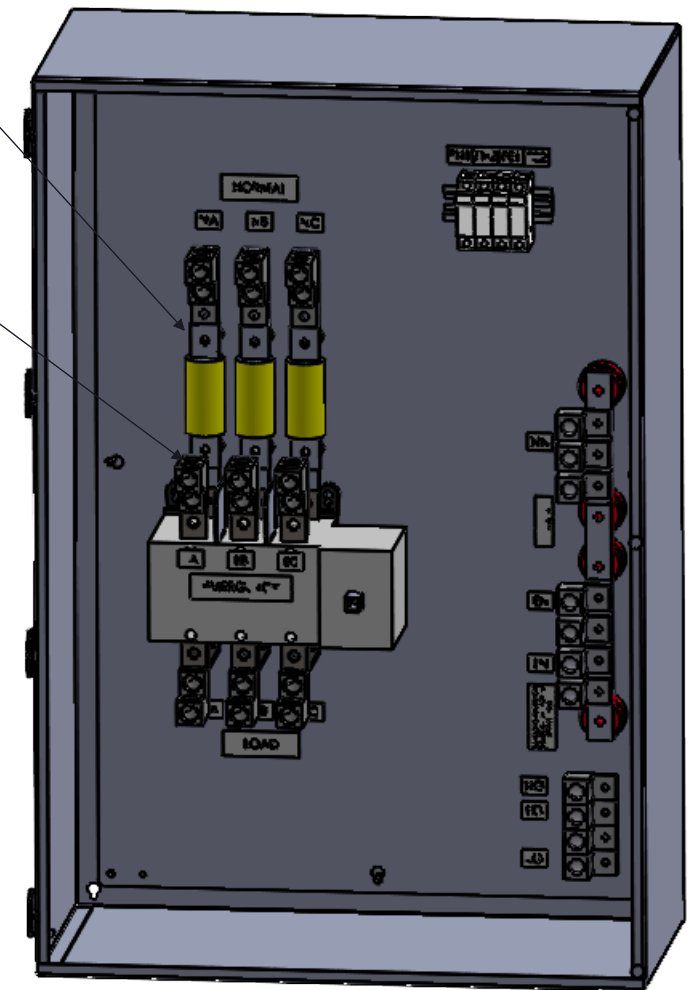

DIMETRIC VIEW  
DOOR REMOVED

NOTE: FUSES PROVIDED IF PURCHASED  
208-240VAC : FRN-R-200  
480VAC : LPJ-200SP



9900 TWIN LAKES PARKWAY  
CHARLOTTE, NC 28269  
704-596-5617  
PSICONTROLSOLUTIONS.COM

100A SE-RATED 3-POLE NEMA 1 MANUAL TRANSFER SWITCH

REV	DESCRIPTION	DATE	DRAWN	C. JUNG
0	ORIGINAL RELEASE	9/15/17	CHECKED	
1	FUSES MOVED	10/19/21	SUP. NO	
2	HARD BUS ADDED	02/07/22	SUP. BY NO	
			PANEL NO	
			BUL. NO	
			GROUP NO	
			ORDER NO	

DRAWING TYPE  
**OUTLINE**  
DRAWING NUMBER  
**STS100N1SE3**