

SPECIFICATIONS

MAX VOLTAGE - 600VAC 3Φ
 CURRENT RANGE - 400A
 STANDARDS - UL1008
 SUITABLE FOR USE AS
 SERVICE EQUIPMENT
 ENCLOSURE RATING - NEMA 3R
 REF ES11BTS3A
 EST SHIPPING WEIGHT - 150 LBS

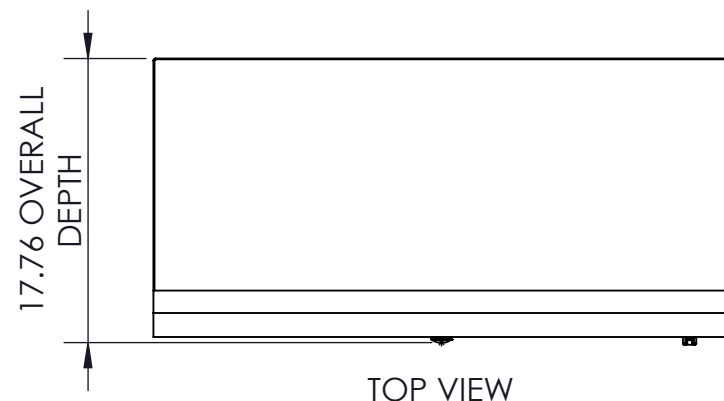

TOP VIEW

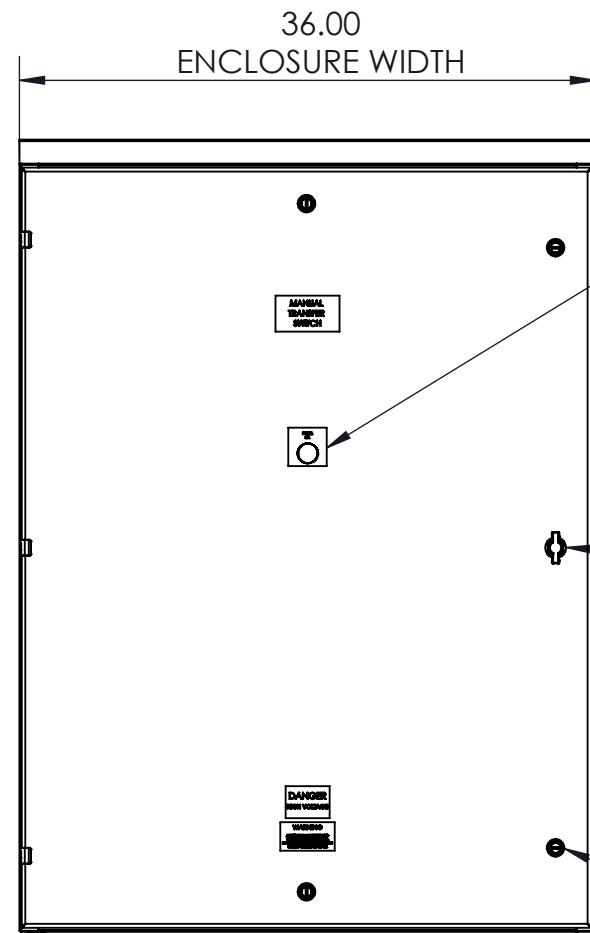

FRONT VIEW

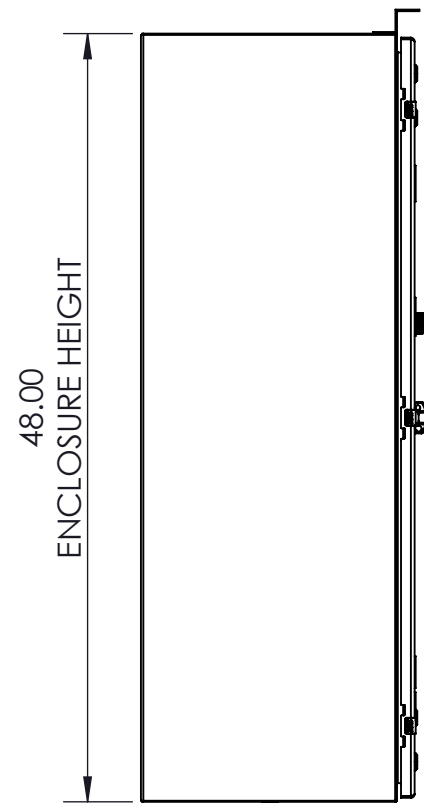

SIDE VIEW

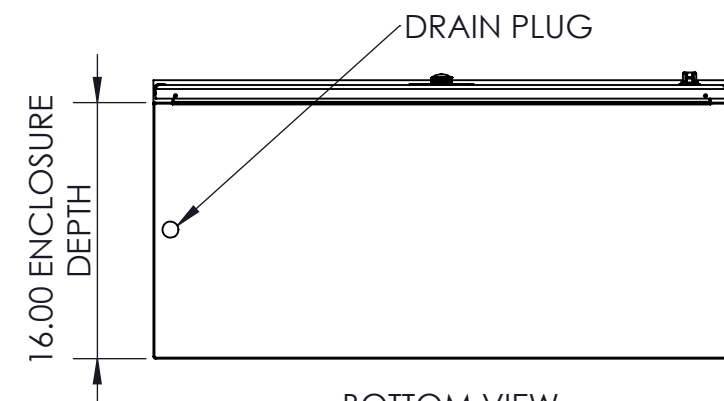

BOTTOM VIEW

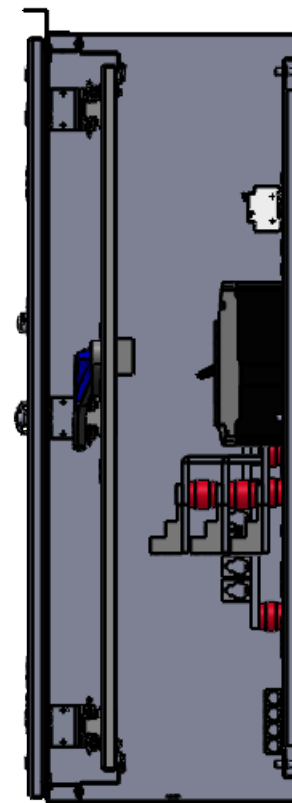

SIDE VIEW

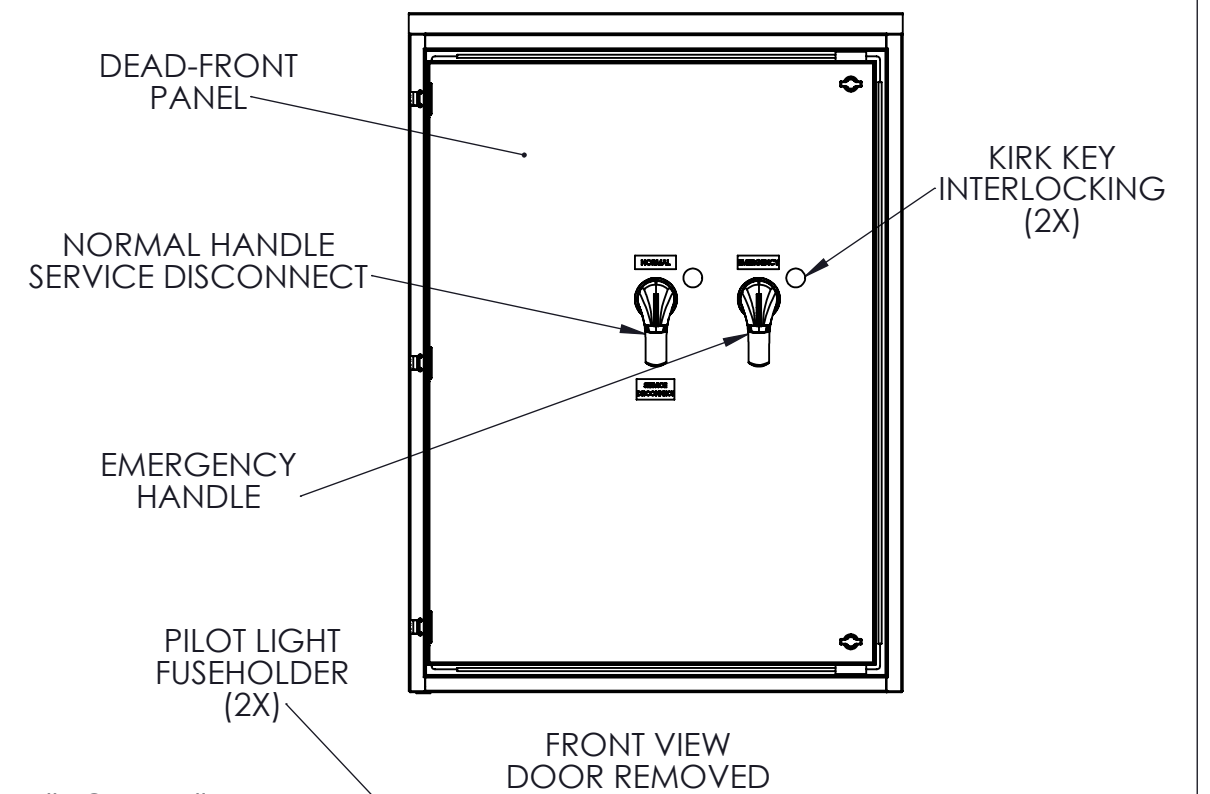

FRONT VIEW DOOR REMOVED

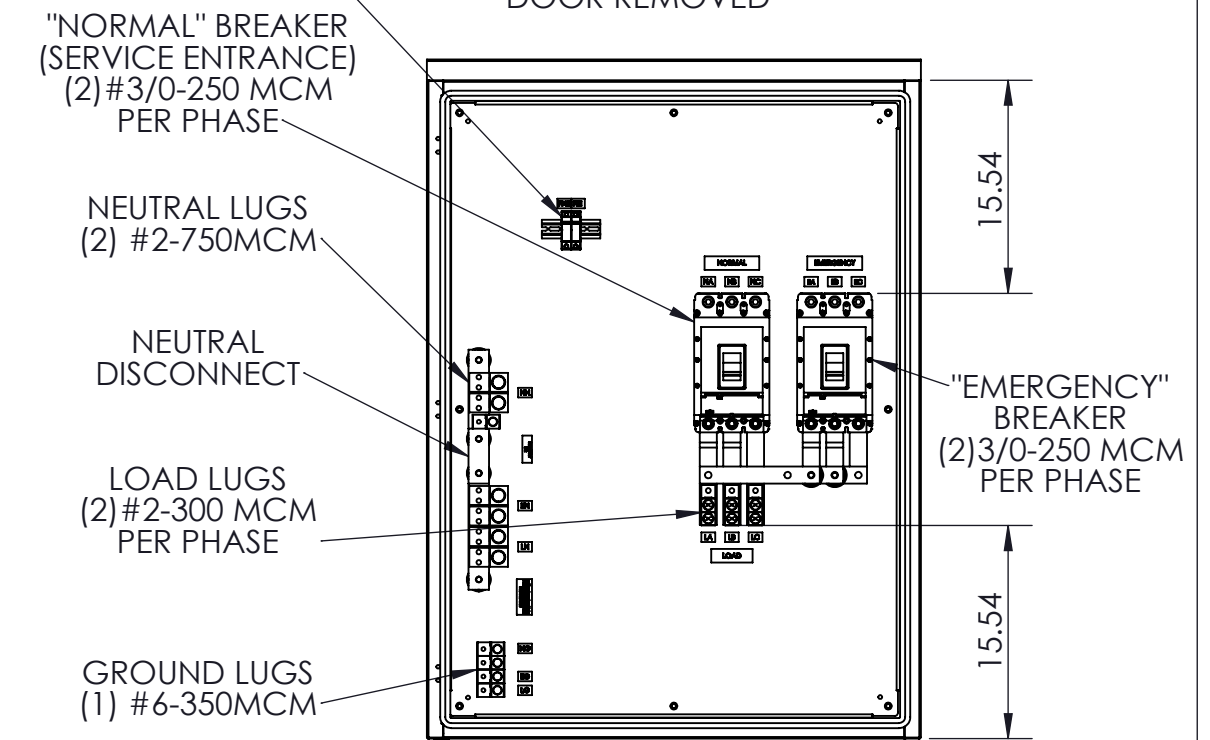

FRONT VIEW DOOR/DEADFRONT REMOVED

NOTE:
 BREAKERS ARE KIRK KEY INTERLOCKED.
 ONLY ONE CAN BE ENERGIZED AT A TIME

PSI Power & Controls
 9900 TWIN LAKES PARKWAY
 CHARLOTTE, NC 28269
 704-596-5617
 PSICONTROLSOLUTIONS.COM

400A NEMA 3R BREAKER-BREAKER TRANSFER SWITCH			
REV	DESCRIPTION	DATE	DRAWN C. JUNG
0	ORIGINAL RELEASE	2/8/17	CHECKED
1	ENCLOSURE CHANGED	1/27/22	SUP. NO
			SUP. BY NO
			PANEL NO
			BUIL. NO
			GROUP NO
			ORDER NO

DRAWING TYPE	DIMENSIONAL
DRAWING NUMBER	BTS400N3RSE3A